

TECHNICAL MANUAL

MODEL D87-250 HANDWHEEL OVERTORQUE PROTECTOR

PURPOSE

Model D87-250 Valve Overtorque Protectors prevent valve damage caused by use of excessive operating torque.

OPERATION

Operating torque is applied to the shaft. The torque is transmitted through the D87 mechanism and into the valve/actuator. If excessive torque is applied, the D87 drive will disengage and prevent damage. Operation is the same in either direction of rotation. Re-engagement is automatic.

CONSTRUCTION

The mechanism is permanently lubricated and hermetically sealed inside a rugged cast-iron housing that is corrosion protected by epoxy coating.

DIMENSIONS and MOUNTING

The unit is mounted directly on the valve/actuator input shaft. No special tools or valve/actuator modifications are required. To mount: Place D87 on the valve/actuator input shaft and tighten the two stainless steel mounting screws.

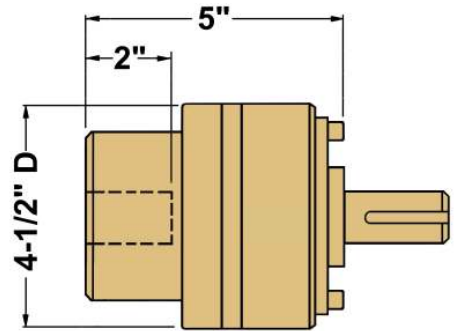

SHAFT & BORE AS SPECIFIED

END CONNECTIONS

Input: Shaft as required. Output: Bore as required

OPERATING RANGES

Trip Torque: 100 to 250 lbft

Temperature: -20 F to 200 F (Higher temperature models available)

TRIP TORQUE ADJUSTMENT

Units are shipped full calibrated and ready to mount. The trip torque calibration screw is concealed to prevent tampering. Trip torque can be adjusted by the following procedure:

1. Remove the shaft from the bonnet to expose the calibration screw.
2. Rotate the calibration screw inward (CW) to increase trip torque, or outward (CCW) to decrease. One-sixteenth revolution will change trip torque about 10 lbft.
3. After calibration put a drop of Loctite 290 liquid on threads. Replace shaft.



Aunspach Controls Company, Inc.

4648-C Russell Court,
High Ridge, MO. 63049

Ph: (636) 376.2395

Fx: (314) 576.7587

email: sales@aunspachcontrols.com

www.aunspachcontrols.com

CAUTION

HANDWHEEL OVERTORQUE PROTECTORS

When *Handwheel Overtorque Protectors* are used with chain wheel or similar applications the following safety measure must be taken:

1. All *Handwheel Overtorque Protectors* must be equipped with a Safety Restraint (PN: A10375), and the Safety Restraint attached firmly to a solid support. This is to prevent the *Overtorque Protector* from falling in event of a broken actuator shaft or other support failure.
2. Unless the handwheel is securely pinned to the *Overtorque Protector* shaft, the *Overtorque Protector* must be equipped with a retaining ring installed in a groove at the shaft end to prevent the handwheel from being pulled off of the shaft. Grooved shaft to be specified with order.
3. Unauthorized partial or complete disassembly of any *Overtorque Protector* will void all warranties.

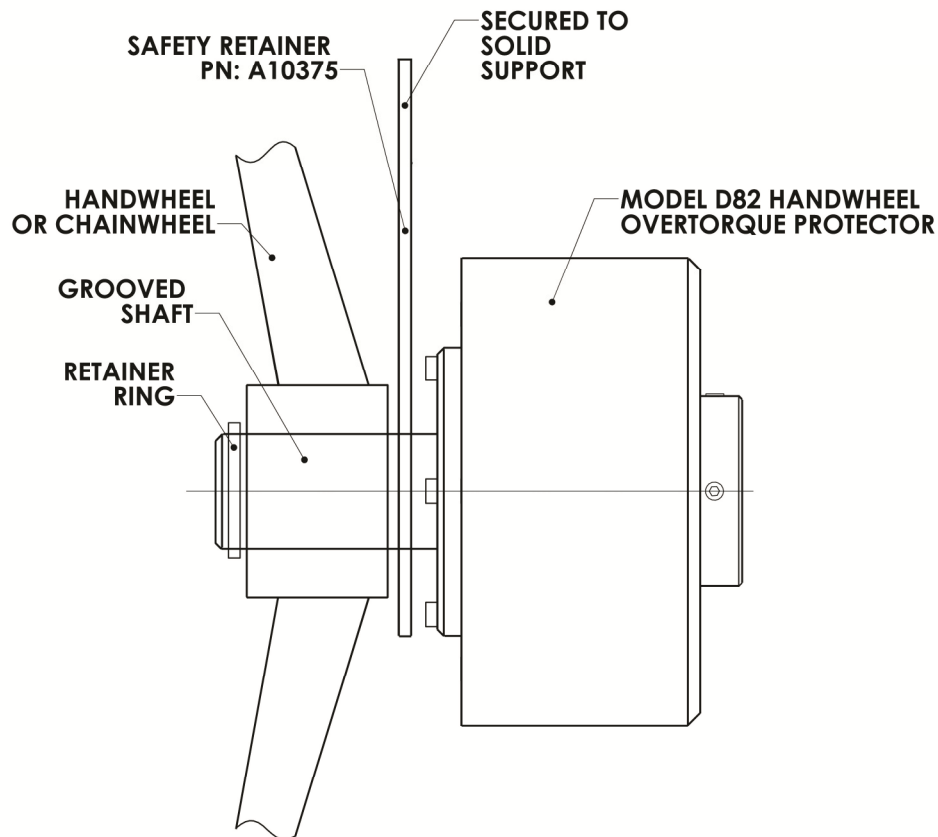

Aunspach Controls Company, Inc
4648C Russell Court, High Ridge, MO 63049
Ph: 636-376-2395 Fx: 314-576-7587
www.aunspachcontrols.com
sales@ aunspachcontrols.com