

# TECHNICAL MANUAL

## MODEL D82TM HANDWHEEL OVERTORQUE PROTECTOR

### Purpose

The purpose of the Model D82TM Handwheel Overtorque Protector is to prevent equipment damage by limiting the amount of operating torque that can be applied.

### Description

Model D82TM is designed for electric actuators that have top-mounted handwheels. It is also applicable for manual gear actuated equipment with bolt-mounted handwheels. The D82TM is mounted in place of the existing handwheel.

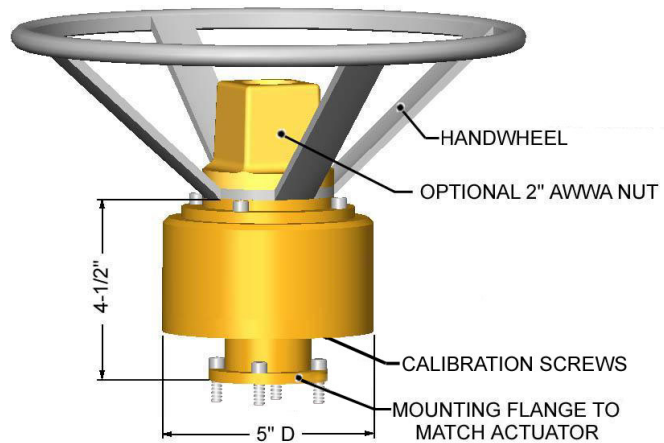

*Overall height and handwheel diameter depend upon handwheel specified. Optional AWWA Operating Nut adds 2.5 inches to the 4.5 inch dimension.*

### Operation

Operating torque is applied to the handwheel and transmitted through the Model D82TM to the actuator or driven equipment. If excessive torque is applied the D82TM drive mechanism will disengage and the damaging torque will not be transmitted. Re-engagement is automatic. Operation is the same in either direction of rotation.

### Construction and Corrosion Protection

The D82TM is designed for thousands of dependable operations without maintenance. The mechanism is permanently lubricated and hermetically sealed inside a rugged housing. Units are corrosion protected by stainless steel components and epoxy coating.

### Trip Torque Range

Standard Model D82TM trip torque range is 3 lbft to 100 lbft. Higher capacity models are available.

### Calibration

Model D82TM units are factory calibrated to user specifications. To re-calibrate, turn each of the three calibration screws, located as shown in illustration above, an equal amount. Turn the screws inward to increase trip torque and outward to decrease. After calibration, apply a drop of Loctite 290 to each screw to lock the calibration and seal the threads.

### Mounting

To mount the D82TM, remove the existing handwheel and bolt the D82TM in its place. No equipment modification is required.

### Maintenance

No Maintenance is required.



**Aunspach Controls Company, Inc**  
1897 McKelvey Hill Drive, St Louis, MO 64043  
4648C Russell Court, High Ridge, MO 63049  
Ph: 636-376-2395 Fx: 314-576-7587  
[www.aunspachcontrols.com](http://www.aunspachcontrols.com)  
[sales@ aunspachcontrols.com](mailto:sales@ aunspachcontrols.com)

# MODEL D82TM

## TRIP TORQUE vs CALIBRATION SCREW POSITION

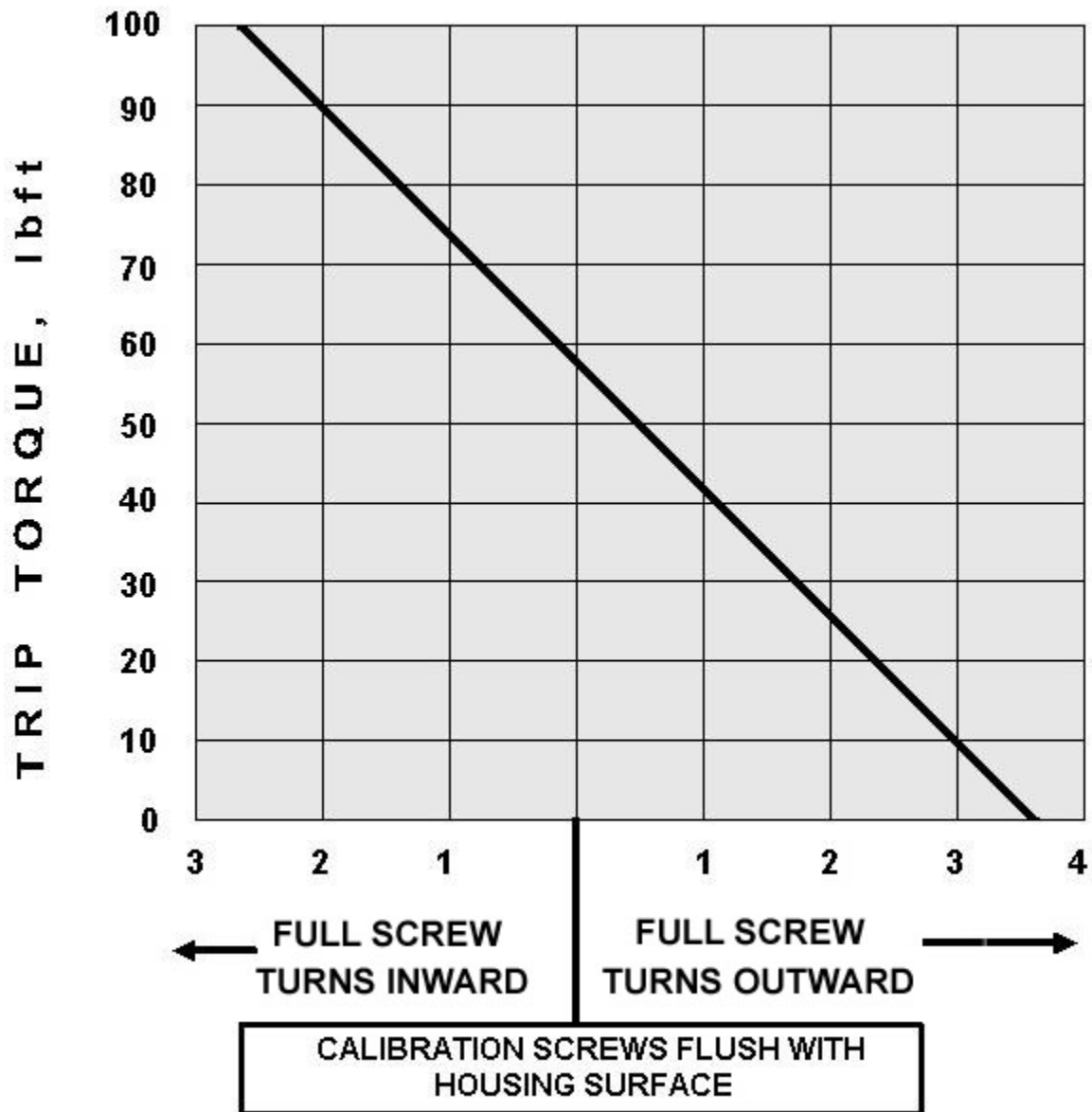

The calibration information above is representative of all Model D82TM and D82 Models. Contact factory if more precise calibration of individual units is desired.

To calibrate, turn each calibration screw an equal amount in or out, not more than 1/2 turn at a time.

**Aunspach Controls Company, Inc**